



Screw Pocket Machine Owner's Manual

SPM301, SPM301HD & SPM301NE



SPM301 Screw Pocket Machine
Proudly made in the USA

www.safetyspeed.com



Read and understand this manual before operating this tool. Failure to follow the safety precautions and instructions can result in serious injury or death. Keep this manual in an accessible and safe location for future reference.

A message from all of us at SAFETY SPEED MANUFACTURING:

Thank you for purchasing a Safety Speed Manufacturing (SSM) Pocket Screw Machine. We take pride in building these fine products in the U.S.A.

Each SSM product is designed to give years of dependable service. Your new pocket screw machine was built from the finest components available, and every machine is individually assembled by craftsmen - some of whom have been building our products for more than 25 years. We appreciate you choosing SSM products for your facility.

Team Safety Speed,
Ham Lake, Minnesota

Limited Warranty

Safety Speed Manufacturing (SSM) warrants the parts and workmanship of this tool, except for the electric motor(s), for one year from the date of purchase. SSM will repair or replace, at our discretion, any component that is determined to be defective. Repair or replacement is limited to providing replacement parts from the factory. SSM assumes no responsibility for making repairs on site. Parts returned to the factory must be returned freight prepaid and include a Return Authorization (R.A.) number. Please call SSM 763-755-1600 for a R.A. number.

All motors are warranted directly by the motor manufacturer. See local repair and maintenance centers for warranty claims for motors.

Safety Speed Manufacturing assumes no responsibility for any damage or accidents resulting from the misuse of this tool, its misapplication, or failure to follow precautionary safety measures. SSM assumes no responsibility for any consequential damage or loss of production. SSM will not be responsible for claims made for machines that are not used or maintained in the normal course of business, used for applications not intended, or modified in any way. This warranty gives you specific legal rights, and you may also have other rights which vary from state to state. SSM # 763-755-1600.

This manual applies to the following SSM Screw Pocket Machines:

SPM301

SPM301HD

SPM301NE
(Non-Electric)

Enter your model number and serial number for quick and easy reference when ordering accessories, supplies or parts.

Note: The Model and Serial Number label of the SPM301 variations can be found inside on the left, upper side of the cabinet on top of the electronics enclosure. Note: The cover must be open to view serial label. (Fig. 1).

Model No: _____

Serial No: _____

Safety Speed Mfg.
13943 LINCOLN ST. NE
HAM LAKE, MN 55304
1 763-755-1600

Serial & Model
Label

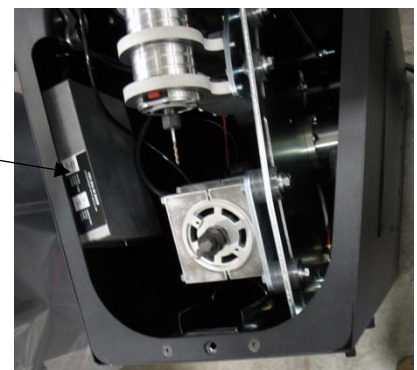

Figure 1: Serial & Model label

CONTENTS

Safety.....	4
Safety & Warning Label Placement.....	4
Safety & Warning Labels Identified.....	5
Safety Procedures.....	6
Proposition 65 Warning.....	8
Electrical Safety.....	9
Extension Cords.....	10
Short-Circuit Protection.....	10
Electrical Connections.....	11
Screw Pocket Machine Components.....	12
Inventory.....	12
Unpacking.....	13
Installation/Set Up.....	14
Tools Required for Installation.....	14
Operating Environment.....	14
Installing a Router Bit.....	15
Selecting Bits.....	16
Installing a Drill Bit.....	17
Operation.....	19
Capacities of the Machine.....	19
Variable Cycle Speed.....	20
<i>Janka</i> Hardness Chart.....	22
Pocket Depth Adjustment.....	23
Selecting Screws.....	24
Depth Gauge.....	25
Pocket Hole Positioning.....	26
Fence Adjustment.....	26
Perpendicular Guide Adjustment.....	27
Maintenance.....	28
General Maintenance.....	28
Cleaning.....	28
Maintaining Motors.....	29
Service.....	29
Removing Motors.....	29
Installing Motors.....	30
Adjusting the Guide Arms.....	31
Lubricating the Guide Arms & Bushings.....	32
Replacement Parts & Repairs.....	32
Adjusting the 3-Way (Poppet) Valve.....	33
Dust Collection.....	34
Specifications.....	35
Accessories.....	35

SAFETY

Read and understand this manual before operating this tool. Failure to follow the safety precautions and instructions can result in serious injury or death. Keep this manual in an accessible and safe location for future reference. Electronic copies of this manual are available at www.safetyspeed.com. Printed copies are available by calling SSM 763-755-1600.

DANGER

Indicates a hazardous situation which, if not avoided, will result in death or serious injury.

WARNING

Indicates a hazardous situation which, if not avoided, could result in death or serious injury.

CAUTION

Indicates a potentially hazardous situation, which if not avoided, could result in minor or moderate injury.

Safety & Warning Label Placement

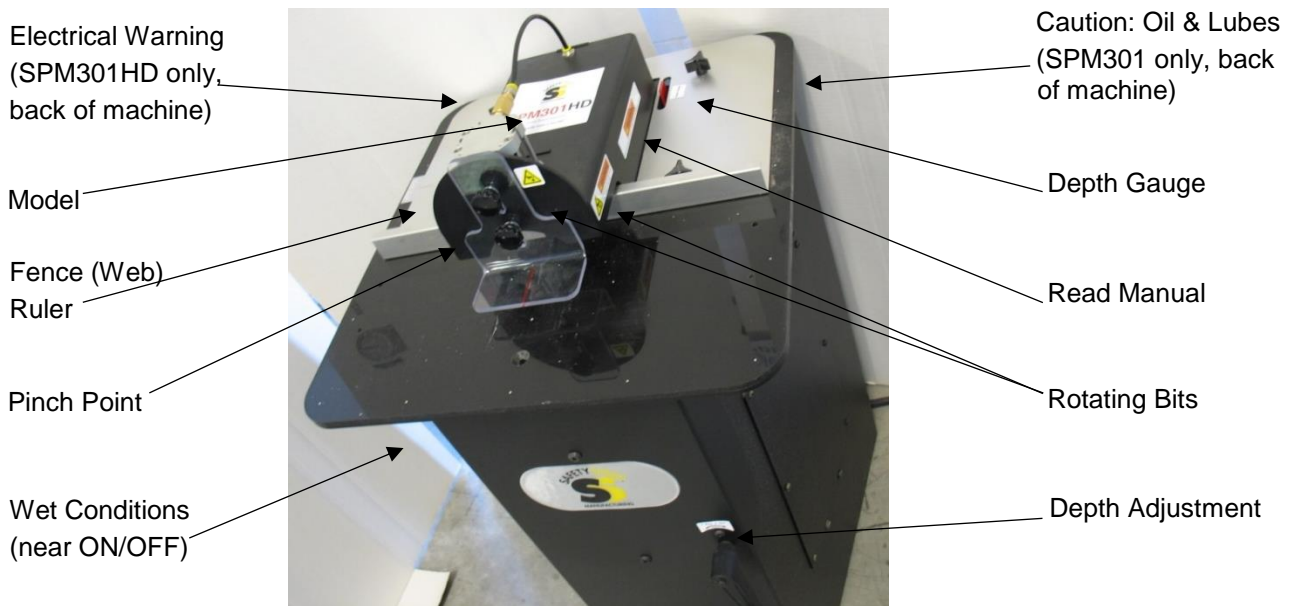
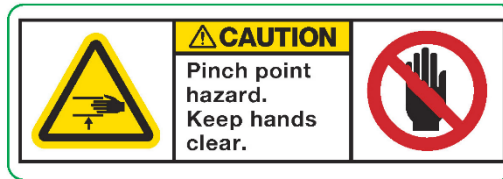

Figure 2: Safety & Warning Label Locations (SPM301 shown)

Safety Warning Labels Identified



Do Not Place Hands Under Guard



Keep Hands Clear Of Area To Prevent Pinching



Do Not Place Hands Under Guard



SPM301 ONLY! Do Not Use Oil In Air System



Disconnect Power Before Opening



Do Not Operate In Wet Conditions

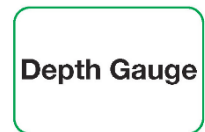

Depth Gauge



Read Manual Before Operating

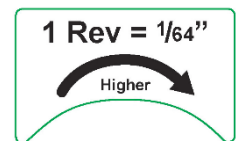

Clockwise Raises Pocket

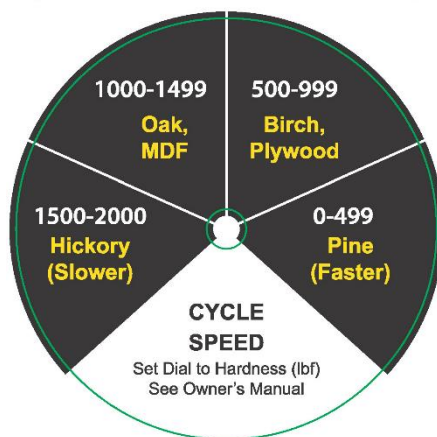

Cycle Speed Selection



Keep Hands Away

When using electric tools, always follow basic safety precautions to reduce the risk of fire, electric shock, and personal injury.

READ AND SAVE ALL INSTRUCTIONS FOR FUTURE USE. Before use, be sure everyone using this tool reads and understands this manual as well as any labels packaged with or attached to the machine.

1. **KNOW YOUR POWER TOOL.** Read this manual carefully to learn your power tool's applications and limitations as well as potential hazards associated with this type of machine.
2. **DO NOT ALLOW UNQUALIFIED PEOPLE TO OPERATE** the machine.
3. **AVOID DANGEROUS ENVIRONMENTS.** Do not use your power tool in rain, damp or wet locations, or in the presence of explosive atmospheres (gaseous fumes, dust, or flammable materials). Remove materials or debris that may be ignited by sparks.



4. **KEEP WORK AREA CLEAN AND WELL LIT.** Cluttered, dark work areas invite accidents. Provide at least 200 watts of lighting at the front work area of the tool. Eliminate all shadows that could interfere with clear viewing of the work area.
5. **DRESS PROPERLY.** Do not wear loose-fitting clothing or jewelry. Wear a protective hair covering to contain long hair, as it may be caught in moving parts. When working outdoors, wear rubber gloves and insulated, nonskid footwear. Keep hands and gloves away from moving parts.
6. **USE SAFETY EQUIPMENT.** Everyone in the work area should **wear safety goggles or glasses with side shields** that comply with current safety standards. Wear hearing protection during extended use and a dust mask for dusty operations. Hard hats, face shields, safety shoes, etc. should be used when specified or necessary. Keep a fire extinguisher nearby.
7. **KEEP BYSTANDERS AWAY.** Keep children and bystanders at a safe distance from the work area to avoid distracting the operator and contacting the machine or extension cord.
8. **MAKE THE WORKSHOP CHILD PROOF** with padlocks, master switches, etc.
9. **NEVER LEAVE THE MACHINE RUNNING UNATTENDED.** Turn the power OFF. Do not leave the tool until it comes to a complete stop.
10. **PROTECT OTHERS IN THE WORK AREA** from debris such as chips and sparks. Provide barriers or shields as needed.
11. **SECURE THE WORK.** Use a clamp, vise, or other practical means to hold your work securely, freeing both hands to control the tool.
12. **USE THE RIGHT TOOL.** Do not use a machine or attachment to do a job for which it is not recommended. For example, do not use a circular saw to cut tree limbs or logs. Do not alter the tool, remove guards, or operate the pocket screw machine, router or drill when removed from the carriage and frame.
13. **USE PROPER ACCESSORIES.** Using non-recommended accessories may be hazardous. Be sure accessories are properly installed and maintained. Do not defeat a guard or other safety device when installing an accessory or attachment.
14. **CHECK FOR DAMAGED PARTS.** Inspect guards and other parts before use. Check for misalignment, binding of moving parts, improper mounting, broken parts, and any other conditions that may affect operation. If abnormal noise or vibration occurs, turn the machine off immediately and have the problem corrected before further use. Do not use a damaged tool. Tag damaged tools "DO NOT USE" until repaired. Repair or replace a damaged guard or other part. For all repairs, insist on identical replacement parts or factory certified conversions.
15. **REMOVE ALL ADJUSTING WRENCHES, TOOLS and GUIDES** from the machine before turning it on. Make this a habit.

16. GROUND YOUR MACHINE. See "Electrical Safety," page 9.
17. AVOID ACCIDENTAL STARTING. Be sure your tool is turned OFF before plugging it in. Do not use the machine if the power switch does not turn it on and off. Observe correct Lockout/Tagout procedures when performing maintenance on the machine.
18. DO NOT FORCE THE MACHINE. Your tool will perform best at the rate for which it was designed. Excessive force only causes operator fatigue, increased wear, increased risk of binding or sudden breakage, and reduced control.
19. KEEP HANDS AWAY FROM ALL CUTTING EDGES, MOVING PARTS AND PINCH POINTS.



20. DO NOT ABUSE THE CORD. Never unplug the cord by yanking it from the outlet. Pull the plug rather than the cord to reduce the risk of damage. Keep the cord away from heat, oil, sharp objects, cutting edges, and moving parts.
21. DO NOT OVERREACH. MAINTAIN CONTROL. Keep proper footing and balance at all times. Maintain a firm grip.
22. STAY ALERT. Watch what you are doing, and use common sense. Do not use a tool when you are tired, distracted, or under the influence of drugs, alcohol, or any medication causing decreased control.
23. UNPLUG THE MACHINE/DISCONNECT POWER when it is not in use, before changing items such as bits and before performing recommended maintenance. Observe appropriate Lockout/Tagout procedures.
24. MAINTAIN TOOLS CAREFULLY. Keep handles dry, clean, and free from oil and grease. Keep cutting edges sharp and clean. Follow instructions for lubricating and changing accessories. Periodically inspect machine cords and extension cords for damage. Have damaged parts repaired or replaced.
25. MAINTAIN LABELS AND NAMEPLATES. These carry important information. If unreadable or missing, contact Safety Speed for a free replacement.



26. DO NOT USE PUSH STICKS.
27. ALWAYS WAIT FOR THE BITS TO STOP COMPLETELY BEFORE CHANGING POSITIONS. Unplug the machine and disconnect the air supply before transporting or moving it.
28. DO NOT PLACE YOUR HANDS ON OR UNDER THE GUARDS, CLAMPS OR IN THE PATH OF THE BITS. Do not try to retrieve a piece of material while the bits are rotating. This symbol is to remind you:



29. DO NOT DEFEAT THE GUARDS OR OPERATE THE MACHINE WITHOUT THE GUARDS IN PLACE. Do not remove the router motor, drill motor or cycle motor from the mounting plate or carriage.

30. NEVER STAND ON THE MACHINE. Serious injury could occur if the machine is tipped or if you unintentionally contact the cutting bits.
31. HOME CENTERS AND COMMERCIAL LOCATIONS should check as part of the installation with their local electrical contractor to be sure the proper amount of electrical power (volts/amps) and/or air supply will be available for this machine during all operating hours and conditions. Be aware of any special electrical safety requirements for this machine (examples: key lock offs, timers, coded security, touch pads, disconnects, or time lockouts) required by local codes.
32. DISCONNECT AND LOCK THE POWER OFF before changing bits or making any adjustments.
33. BEFORE CONNECTING THE MOTOR(S) TO THE POWER SUPPLY BE SURE THE MOTOR SWITCH IS IN THE OFF POSITION.
34. KEEP THE TOP COVER TIGHTENED and in place when the machine is not in use.
35. DO NOT PLACE HANDS UNDER GUARDS OR IN LINE WITH BIT TRAVEL. Be aware of potential pinch points. Only hold or operate machine with designated handles.



36. REFER TO PAGE 5 FOR WARNING LABEL IDENTIFICATION.

Please Read Before Operating the Pocket Screw Machine



Some dust created by power sanding, sawing, grinding, drilling, and other construction activities contains chemicals known to cause cancer, birth defects or other reproductive harm. Some examples of these chemicals are:

- Lead from lead-based paint
- Crystalline silica from bricks and cement and other masonry products, and
- Arsenic and chromium from chemically treated lumber.

Your risk from these exposures varies, depending on how often you do this type of work. To reduce your exposure to these chemicals: work in a well ventilated area, and work with approved safety equipment, such as those dust masks that are specifically designed to filter out microscopic particles. **For more information go to www.P65Warnings.ca.gov/wood**

Electrical Safety



Improperly connecting the grounding wire can result in the risk of electric shock. Check with a qualified electrician if you are not sure that the outlet is properly grounded. Do not modify the plug provided with the tool. Never remove the grounding prong from the plug. Do not use the tool if the cord or plug is damaged. If damaged, have it repaired by a qualified electrician before use. If the plug will not fit the outlet, have a proper outlet installed by a qualified electrician.

Some machines are equipped with a polarized plug (one blade is wider than the other). This plug will fit in a polarized outlet only one way. If the plug does not fit fully in the outlet, reverse the plug. If it still does not fit, contact a qualified electrician to install a polarized outlet. Do not change the plug in any way. Double insulation eliminates the need for the three wire grounded power supply system mentioned above.

Do not expose your tool to rain or wet conditions. Water entering a power tool will increase the risk of electric shock.



For best performance and to prevent damage use a dedicated electrical circuit for all SSM tools.

The plug must be connected to a properly grounded outlet (Fig. 3). If the tool should electrically malfunction or break down, grounding provides a low-resistance path to carry electricity away from you, reducing the risk of electric shock.

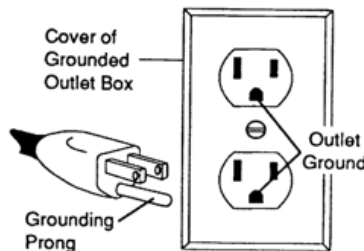

Figure 3: Grounded Plug and Outlet (120 Volt Plug Shown)

The grounding prong on the plug is connected through the green wire inside the cord to the grounding system in the tool. The green wire in the cord must be the only wire connected to the tool's grounding system and must never be attached to an electrically "live" terminal.

The machine must be plugged into an appropriate outlet, properly installed and grounded in accordance with all codes and ordinances. The plug and outlet should look like those in Figure 3 for the SPM301.

Figure 4 illustrates a temporary adapter available for connecting grounded plugs. The green rigid ear or lug extending from the adapter must be connected to a permanent ground such as a properly grounded outlet box or receptacle. Simply remove the center screw from the outlet, insert the adapter and reattach the screw through the green grounding ear to the outlet. If in doubt of proper grounding, call a qualified electrician. A temporary adapter should only be used until a qualified electrician can install a properly grounded outlet. The Canadian Electrical Code prohibits the use of temporary adapters.

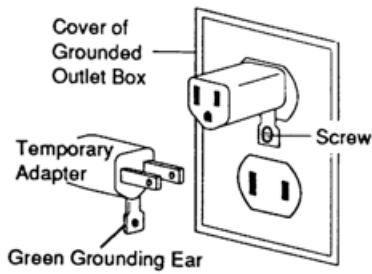

Figure 4: Temporary Grounding Adapter

Extension Cords

Extension cords are NOT recommended. If an extension cord is used, please adhere to the following suggestions. Grounded tools require a three-wire extension cord. As the distance from the supply outlet increases a heavier-gauge extension cord must be used. Extension cords with inadequately sized wire causes a serious drop in voltage, resulting in loss of power and possible motor damage. Refer to Table I below to determine the required minimum wire size.

Table I: Recommended Minimum Wire Gauge for Extension Cords

Nameplate Amps	Extension Cord Length*					
	25'(7.6m)	50'(15m)	75'(23m)	100'(31m)	150'(46m)	200'(61m)
< 5	16	16	16	14	12	12
5 - 8	16	16	14	12	10	—
8 - 12	14	14	12	10	—	—
12 - 15	12	12	10	10	—	—
15 - 20	10	10	10	—	—	—

* Based on limiting the line voltage drop to 5V at 150% of rated amperes.

— Not recommended

The smaller the gauge number of the wire, the greater the ampacity (capacity) of the cord. For example, a 14-gauge cord can carry a higher current than a 16-gauge cord.

Guidelines for Using Extension Cords

For longest motor life and optimum performance extensions cords are NOT recommended.

If you are using an extension cord outdoors, be sure it is marked with the suffix "W-A" ("W" in Canada) to indicate that it is acceptable for outdoor use.

Be sure your extension cord is properly wired and in good electrical condition. Always replace a damaged extension cord or have it repaired by a qualified technician before using it.

Protect extension cords from sharp objects, excessive heat, and damp or wet areas.

Short-Circuit Protection



Only qualified technicians should make electrical connections. Confirm power is OFF/Disconnected before making connections.

This tool must only be wired into a dedicated circuit that has a short-circuit protection device which is located ahead of the equipment in the circuit, in accordance with local codes.

General guidelines are as follows:

SPM301; 110 Volt, Single Phase: min. 20 Amp circuit protection.

SPM301HD; 208-230 Volt, Single Phase: min. 20 Amp circuit protection.

SPM301NE; N/A*

Reference your Model/Serial Label (Pg. 2, Fig. 1) and your local codes before installation.

*N/A = not applicable

Electrical Connections

The SPM301 and SPM301HD screw pocket machine variations require a dedicated circuit that meets the requirements of the motors and local electrical codes. Connect the power cord from the dust collector to a circuit that meets the requirement of the dust collector and all local codes.

Electrical connections should only be completed by a qualified electrician in accordance with all local codes.

The **SPM301** requires a dedicated 110 Volt, 20 Amp circuit and includes a cord and plug.

The **SPM301HD** requires a 20 Amp, 208-230 Volt, single phase dedicated circuit and cord. A minimum 12/4 cord, to be connected to a plug or a disconnect is required. The circuit must include a (N) neutral (common, white), two powered lines (L1 & L2), (red & black), and one (G) ground wire (green or yellow and green). See wiring diagram below (Fig. 5) and inside electrical enclosure on the SPM301HD.

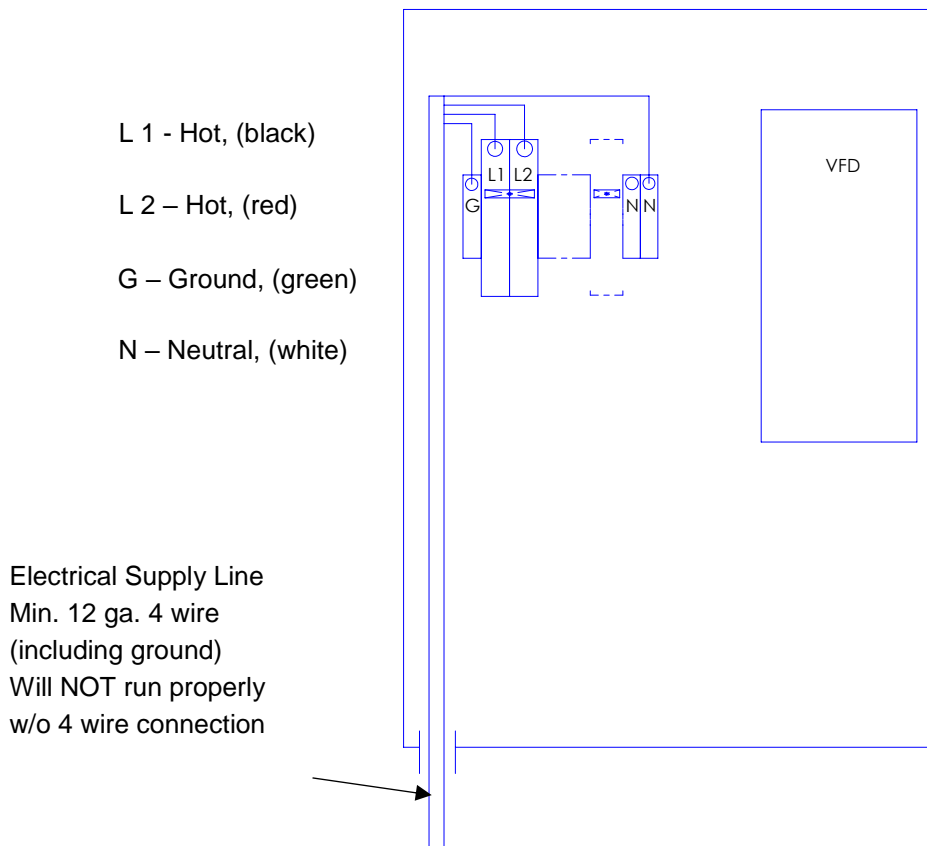

Figure 5: Electrical connections SPM301HD

READ AND SAVE ALL INSTRUCTIONS FOR FUTURE REFERENCE



Read and understand Owner's Manual before operating this machine!

Screw Pocket Machine (SPM) Components

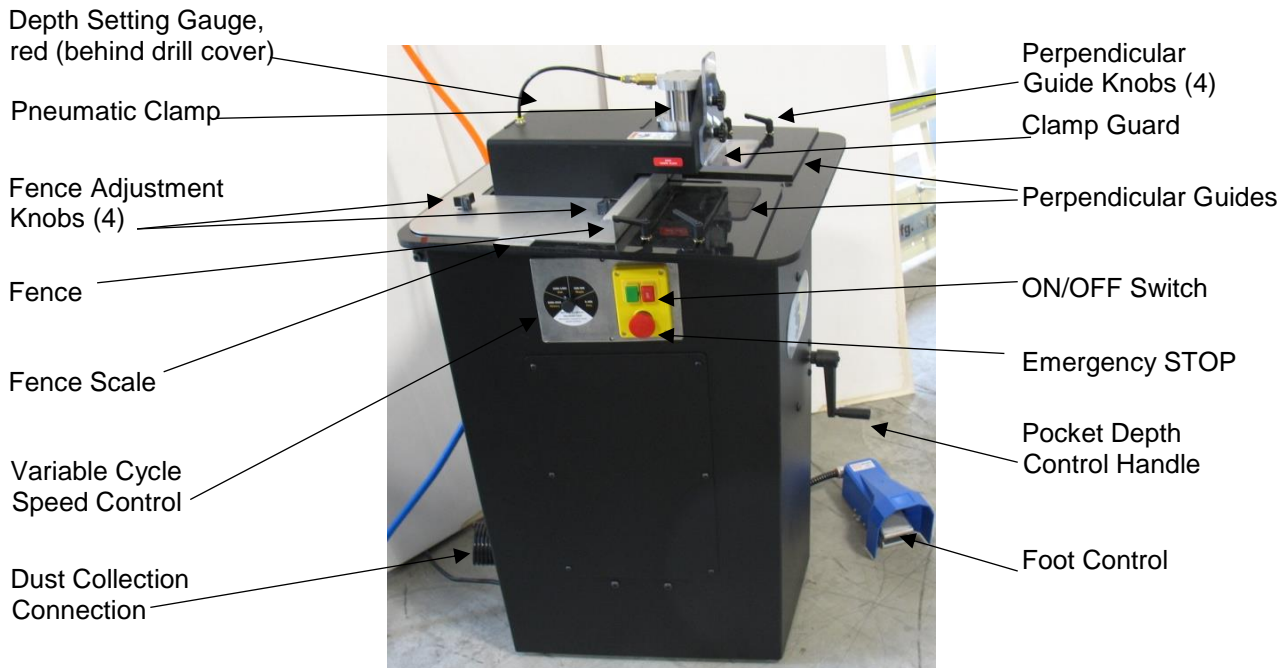

Figure 6: SPM Components

Inventory

Each model includes the frame/stand, fence, foot control, motors, guides, router and drill wrenches and two hex wrenches, router bit and drill bits. The Manual, Collet Wrenches (see Tools Required for Installation, page 14), Spindle Wrench, Bit Gauge, Hex Wrenches and extra drill bit are included in a separate box or boxes.

The **SPM301 router** includes a 1/2" collet installed and an optional 3/8" router collet with the parts box.

The **SPM301 drill** includes a 1/4" collet.

The **SPM301HD router** includes a 3/8" collet (ER 20), installed. The **SPM301HD drill** includes a 1/4" collet.

NOTE: Sioux Tools offers an optional 9/64" collet for the SPM301HD air drill.

Accessories may be packaged and included with the machine or shipped separately. Carefully remove and inspect all items before assembly and operation.

Unpacking

Removing plastic sheeting, protective cardboard, and wood crating. NOTE: Uncrating material and methods vary by model and accessories. See instructions below.



Have a helper(s) assist in removing crate and machine from pallet.

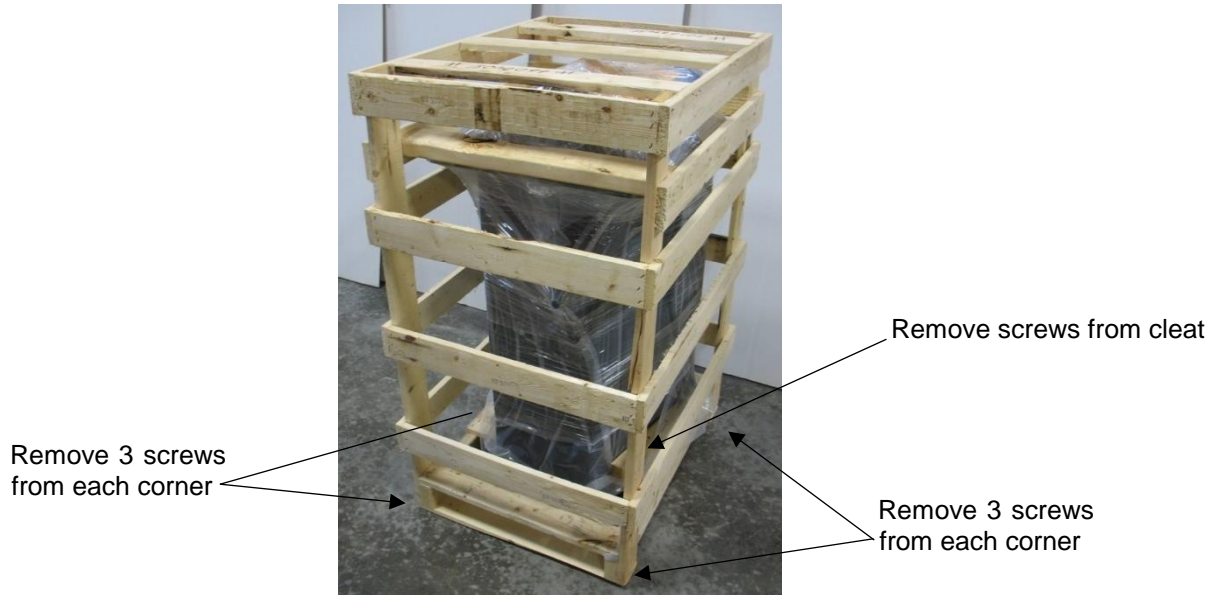

Figure 7: Unpacking

1. Remove screws from bottom of each upright corner piece (Fig. 7), typically three screws per corner.
2. With the help of an assistant, lift crate from machine and pallet, being careful not to damage machine or loose parts (Fig. 8).
3. Remove screws from cleat (Fig. 7 & 8)
4. With the help of an assistant, remove machine from pallet.
5. Place machine in desired location and adjust leveling feet, if necessary, to level and stabilize machine.
6. Remove plastic wrap and other items from top of machine.

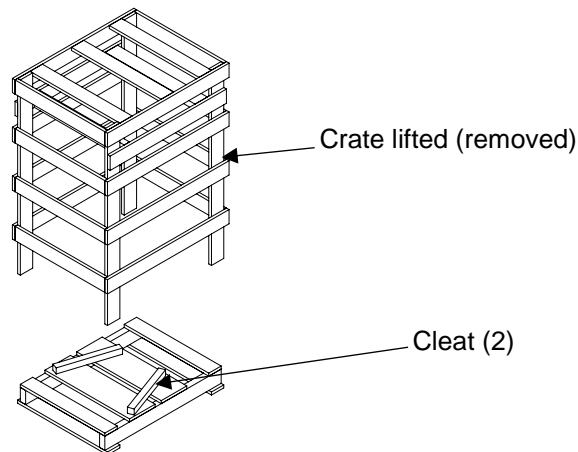

Figure 8: Uncrating

INSTALLATION/SET UP

Your SSM Screw Pocket Machine comes from the factory assembled and aligned. You will only need to place the machine on a level surface and supply power and dust collection and check both the router bit and drill bit. The included leveling feet allow adjustment to prevent “rocking”.

Tools Required for Installation

Note: Additional tools may be required for installing accessories or making adjustments.

MODEL SPM301:

- 17mm wrench – Drill, nut, included
- 22mm wrench – Router, collet, included
- Spanner wrench – Router, nut, included
- 5/32” Hex wrench – Side panels
- 7/32” Hex wrench – Top lock bolt, included

MODEL SPM301HD

- 9/16” wrench – Drill, collet, included
- 3/4” wrench – Drill, nut, included
- 22mm wrench – Router, collet, included
- Spanner wrench – Router, nut, included
- 5/32” Hex wrench – Side panels
- 7/32” Hex wrench – Top lock bolt, included

Operating Environment

For safe operation, install the machine in an area that is well lit. Eliminate all shadows that could interfere with clear viewing of the work area.

Do Not locate the machine in a damp or wet location, or a location where it may be exposed to rain.

SSM strongly recommends installing a dust collector with a minimum of 600 CFM to extend motor and bit life.

Avoid explosive atmospheres (gaseous fumes, dust, or flammable materials).

Secure the area so that children and bystanders are kept a safe distance from the work area. Provide barriers and shields as needed.

NOTE: The average noise level for all the SPM301 models is less than 80 dB.

Initial Set-Up checklist & test:

1. Place machine in desired location.
2. Adjust the four leveling feet (by rotating the feet), if necessary, to prevent “rocking” of machine and to make the machine level.
3. Confirm both the drill bit and router bit are in the correct position by checking with the Bit Gauge (Pgs. 16 & 17, Fig. 10 & 11). Place the Bit Gauge on the Router Motor Mount or Drill Motor Mount, the bit should just touch the bottom of the Bit Gauge. If the bits are not positioned properly, follow the correct “**Installing a Drill/Router Bit**” instructions to adjust.

4. Check both the drill collet and router collect for tightness. Tighten if necessary using the included wrenches, see details in “Installing a Router Bit” or “Installing a Drill Bit”.
5. Attach **clean, dry**, air supply to machine, **minimum 80 PSI**, maximum 150 PSI.
Air use @ 80 PSI: **SPM301, 1-2 CFM; SPM301HD, 30 CFM.**

⚠ CAUTION

If your model includes a pneumatic oiler (e.g. SPM301HD), make sure it is filled with “pneumatic tool oil” before operating machine!

6. Connect electrical supply, see “Electrical Connections” page 11.

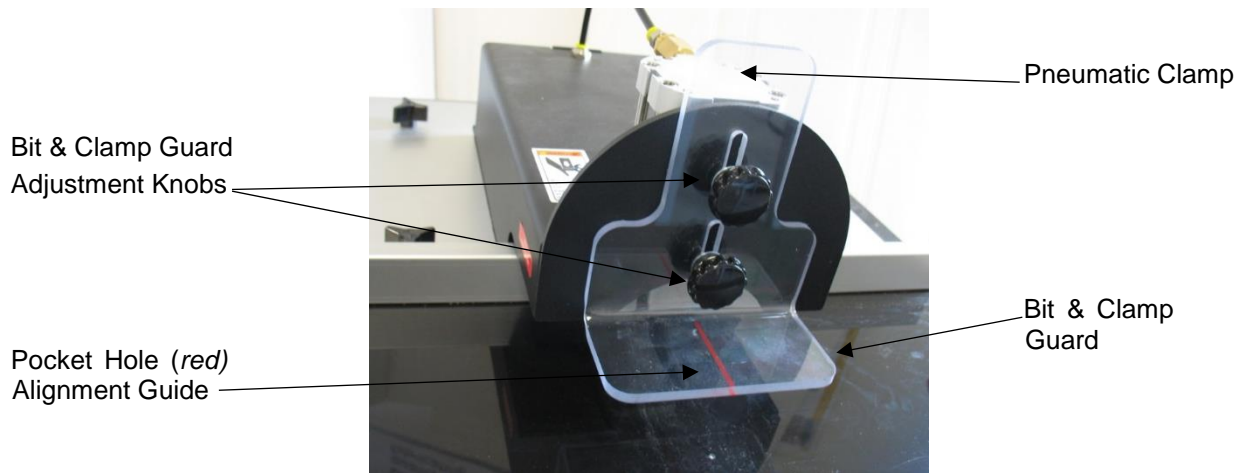

Figure 9: Bit & Clamp Guard

7. Adjust Bit & Clamp Guard (Fig. 9) over test piece, approximately ¼”. Loosen the Clamp Guard Adjustment Knobs (Fig. 9) and adjust Bit & Clamp Guard to allow insertion and removal of material, but so as to NOT allow fingers or hands under or behind the Bit & Clamp Guard during operation. The “Pocket Hole (red) Alignment Guide” (Fig. 9) indicates location of pocket to be cut.
8. **SPM301 only:** Make sure both Router and Drill switches are turned ON.
9. Make a test cut in scrap which is the same thickness as material to be used. Place sample stock against fence and perpendicular guide. Step on the “Foot Control” to activate cycle and remove your foot to complete cycle. Keep your hands away from clamp, bits and Bit & Clamp Guard.
10. See “**OPERATION**” section for making machine adjustments, (e.g. depth of pocket or length of web), if necessary.

Installing a Router Bit

⚠ WARNING

Unplug tool and disconnect air supply before making adjustments, installing bits or accessories. Observe appropriate Lockout/Tagout procedures to insure the tool cannot accidentally be powered.

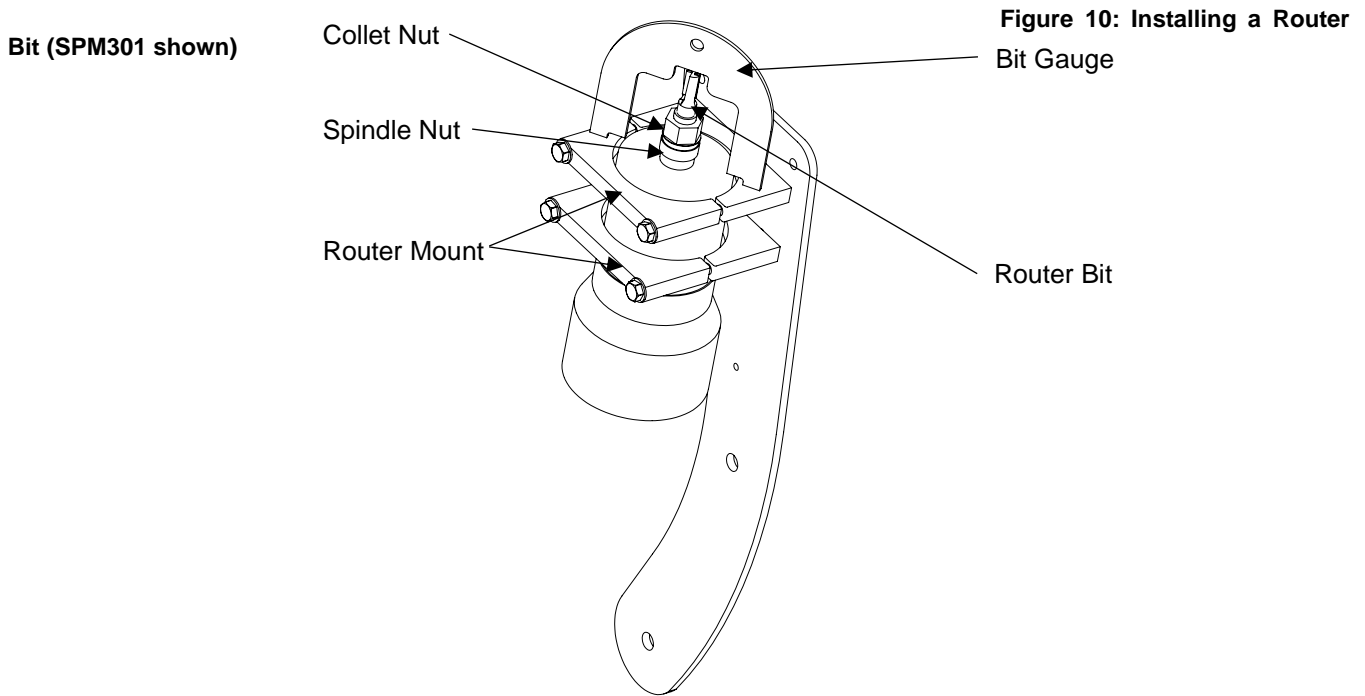

Installing a Router Bit (all models):

1. Unplug tool and disconnect air supply.
2. Select correct router bit for your application.

NOTE: (Contact your machine dealer or SSM (763-755-1600) for help in selecting the appropriate router bit for your materials and applications).

3. Using the wrenches provided, loosen the collet nut (by turning counter clockwise when looking “down”) (Fig. 10), while holding spindle nut. Remove the router bit.
4. Insert new bit into collet. Finger tighten collet nut.
5. Position the Bit Gauge (Fig. 10) against the router mount (Fig. 10) and pull the router bit up against the bottom of the Bit Gauge.
6. Tighten the collect nut securely, while holding the spindle nut.

IMPORTANT: Select the correct bits for your needs. Consult with your machinery dealer, or with the SSM customer service department **(763-755-1600)** to determine the best bits for your application(s).



Always use the supplied Bit Gauge (Fig. 10 & 11) when installing bits.

Always use supplied Bit Gauge (Fig. 10 & 11) when installing bits. Failure to do so could result in the bits colliding with the machine table or the drill when the machine is cycled. If your Bit Gauge is missing or damaged contact Safety Speed for a replacement **(763-755-1600)**.

NOTE: If the Bit Gauge is not available, the router bit should extend 3-1/16" from the top of the "Router Mount". Measure from the top of the router mount to the top of the bit with an accurate and square measuring device. Or call SSM for a temporary solution (763)-755-1600.

Installing a Drill Bit



Unplug tool and disconnect air supply before making adjustments, installing bits or accessories. Observe appropriate Lockout/Tagout procedures to insure the tool cannot accidentally be powered.

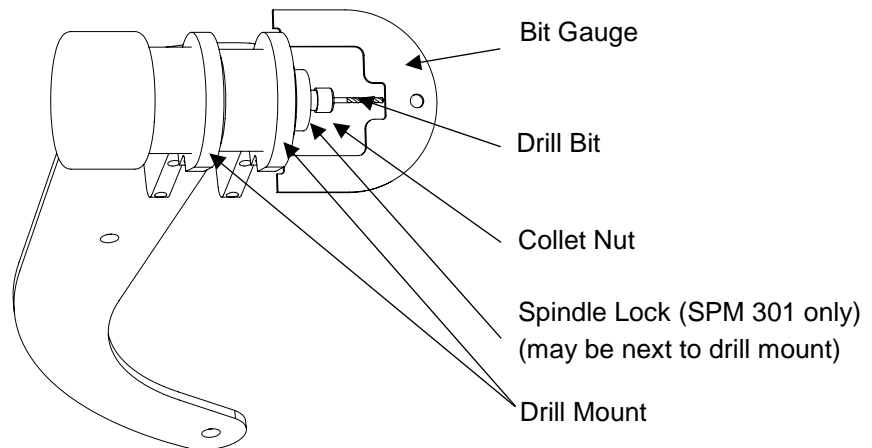

Figure 11: Installing a Drill Bit (SPM301 shown)

SPM301 (electric drill):

1. Unplug tool and disconnect air supply.
2. Using the wrench provided, loosen the collet (by turning nut counterclockwise) (Fig. 11) while holding the (red) spindle lock and remove drill bit.

NOTE: It may be easier to hold the spindle lock with a small stick or other non-sharp object.

3. Select new/sharp drill bit.

NOTE: (Contact your machine dealer or SSM (763-755-1600) for help in selecting the appropriate drill bit for your materials and applications).

4. Insert new drill bit into collet. Finger tighten collet.
5. Position the Bit Gauge (Fig. 11) against the Drill Mount (Fig. 11) and pull the drill bit up against the bottom of the Bit Gauge.

NOTE: If the Bit Gauge is not available, the drill bit should extend 2-7/8" from the top of the "Drill Mount". Measure from the top of the router mount to the top of the bit with an accurate and square measuring device. Or call SSM for a temporary solution (763)-755-1600.

6. Tighten the collect nut securely while holding the (red) spindle lock.



Always use the supplied Bit Gauge (Fig. 10 & 11) when installing bits.

SPM301HD (pneumatic drill):

Figure 12: Installing a drill bit
(SPM301HD shown)

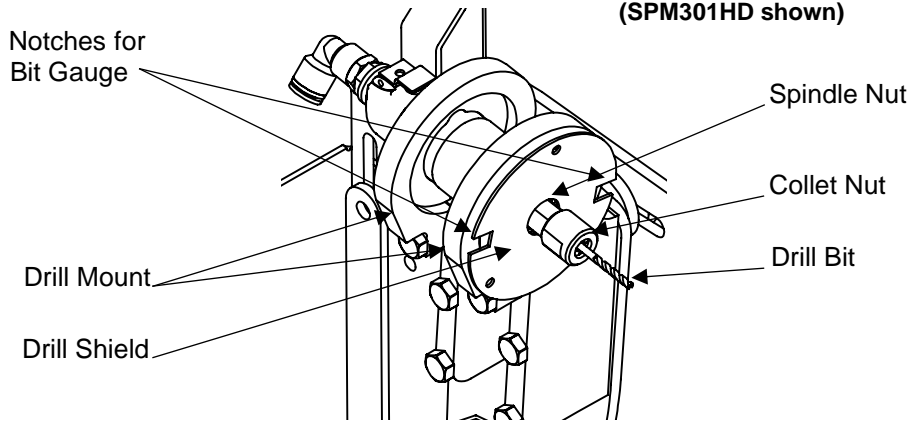

1. Unplug tool and disconnect air supply.

NOTE: The included drill collet and bit is 1/4" diameter. Sioux Tools offers an optional 9/64" collet.

2. Using the wrench kit provided, loosen the collet nut (Fig. 12), while holding the spindle nut, and remove drill bit.

NOTE: The SPM301HD requires two (included) wrenches to loosen and tighten the collet nut.

3. Select new/sharp drill bit.

NOTE: (Contact your machine dealer or SSM (763-755-1600) for help in selecting the appropriate drill bit for your materials and applications).

4. Insert drill bit into collet. Finger tighten collet.
5. Position the Bit Gauge (Fig. 11) into the notches of the Drill Shield and against the drill mount (Fig. 12) and pull the drill bit up against the bottom of the Bit Gauge.
6. Tighten the collect nut securely with the two wrenches.

IMPORTANT: Select the correct bits for your needs. Consult with your machinery dealer, or with our customer service department (**763-755-1600**) to determine the best bits for your application(s).



Always use the supplied Bit Gauge (Fig. 10 & 11) when installing bits.

Always use supplied Bit Gauge (Fig 10 & 11) when installing bits. Failure to do so could result in the bit colliding with the machine table or the router when the machine is cycled. If your Bit Gauge is missing or damaged contact Safety Speed for a replacement (**763-755-1600**).



Always wear proper eye protection when operating machinery. If your Bit Gauge is missing or damaged contact Safety Speed for a replacement.

Always keep bits clean and sharp for the best performance. A dull or dirty bit can bind and pinch, resulting in poor quality cuts. **If in doubt, replace the bit with a new one.**

OPERATION



The following are suggestions that give a general idea of how a Screw Pocket is intended to be operated. No instructions can replace common sense and experience. Be sure all operators have enough time and material to become familiar with the operating characteristics of this machine, and have FULLY READ AND UNDERSTOOD all operating and safety instructions.

Capacities of the Machine



Small Work pieces:

Do not process pieces that are so small that your hand must be behind or under the Bit & Clamp Guard (Pg. 15, Fig. 9). Safety Speed Screw Pocket Machines are not recommended for work pieces that are shorter than the clamp guard. Rails and similarly narrow stock can be positioned using the Perpendicular Guides as long as they extend beyond the clamp guard and have a minimum of 3/8" on each side (offset) of the pocket.

Large Panels:

There is no limit to the size of large panels, as long as they are supported properly. For example, the use of support tables or roller stands can help stabilize long or large panels. When processing large panels, the Perpendicular Guides (Pg.12, Fig. 6) can be removed. This allows large panels to lay flat on the table. Remove the four Perpendicular Guide Knobs (Pg.12, Fig. 6), then remove the two Perpendicular Guides. The Perpendicular Guides and Knobs should be reinstalled for efficiently and quickly processing rails or similar stock.

Work piece thickness:

The Screw Pocket Machines can process material with a thickness range of 1/2" (minimum), through 1-1/2" (maximum).



Do not cut pockets in material less than 1/2" thick. Doing so could result in the workpiece being insufficiently clamped, and could cause bit breakage or operator injury.

Variable Cycle Speed

All models have variable cycle speed control. The speed control adjustment knob is located on the side of the machine (Pg.20, Fig.13) and includes a basic guide for various speed settings. Rotate the knob **counterclockwise** to **reduce** cycle speed and **clockwise** to **increase** cycle speed. Use slower speeds when cutting deep pockets and and/or harder materials. Faster speeds can be used for cutting shallow pockets or softer materials. The correct cycle speeds typically produce more accurate pockets and a better finish.

NOTE: See *Janka* Hardness Chart on Pg. 22 for a wood species hardness reference.

NOTE: If the cycle speed is set too slow, excessive heating of the bits and burning of the stock is possible. Burning can also be an indication of dull bits.

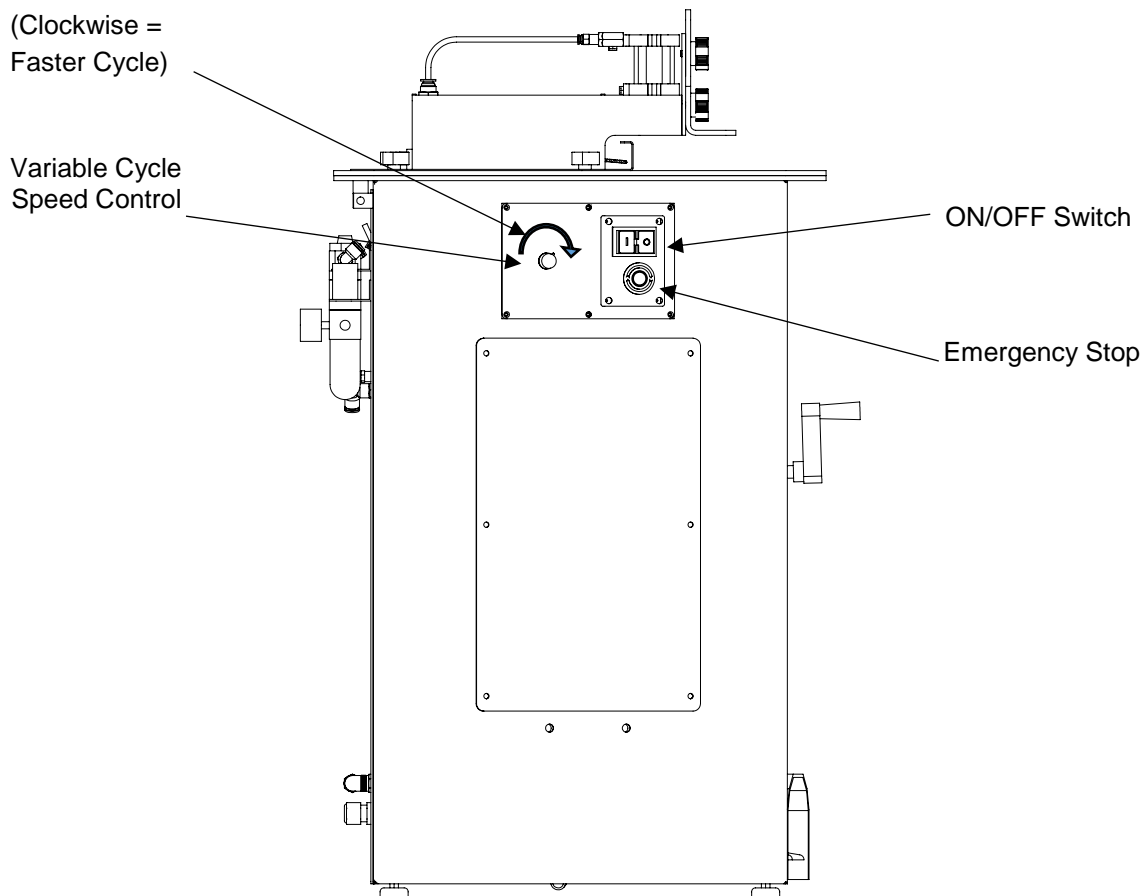

Figure 13: Variable Cycle Speed Control

Cycle Speed must be matched to the materials being machined. Improper speed selection can result in reduced tool life, inaccurate, poor quality cuts, and safety risks. After installing new bits, or when cutting a new material, use a slow cycle speed for the first cut. Gradually increase cycle speed for subsequent cuts until the desired performance is achieved.

NOTE: If in doubt regarding the correct cycle speed, consult with your machinery dealer or call Safety Speed (763-755-1600) to determine the correct settings for your application(s).

 **CAUTION**

When cutting deep pockets, it may be necessary to reduce cycle speed. Using a fast cycle along with deep pockets in hard materials can stall the machine or break the bits.

 **WARNING**

If the router or drill stalls, TURN THE SWITCH OFF and remove the workpiece. Do not turn the switch on and off. A dull bit(s) and/or excess cycle speed may cause stalling.

Janka Hardness Chart

The chart below shows the test results of some of the most common woods species. The *Janka* hardness test measures the resistance of the wood species to denting and wear. The test results shown below were done in accordance with “ASTM D 1037-12” testing methods. Use this chart and the Variable Cycle Speed indicator (by control knob) as a guide to set initial cycle speed for your application(s).

NOTE: Fine tuning the cycle speed may be required for your specific conditions.

The variable cycle speed control located on the side of the machine generally should be matched to the material hardness being cut for optimum performance. Turn the knob **counterclockwise** to **reduce** cycle speed, and **clockwise** to **increase** speed. Use slower speeds when cutting deep pockets in thick material or harder materials. Faster speeds can be used for cutting shallow pockets or soft materials. Slower cycle speeds will generally produce more accurate pockets and a better finish result.

NOTE: MDF & Particle Board typically apply to the “Oak” setting and Plywood the “Birch” setting.

NOTE: Fine tuning the cycle speed may be required for your specific conditions.

Table II: *Janka* Hardness Chart

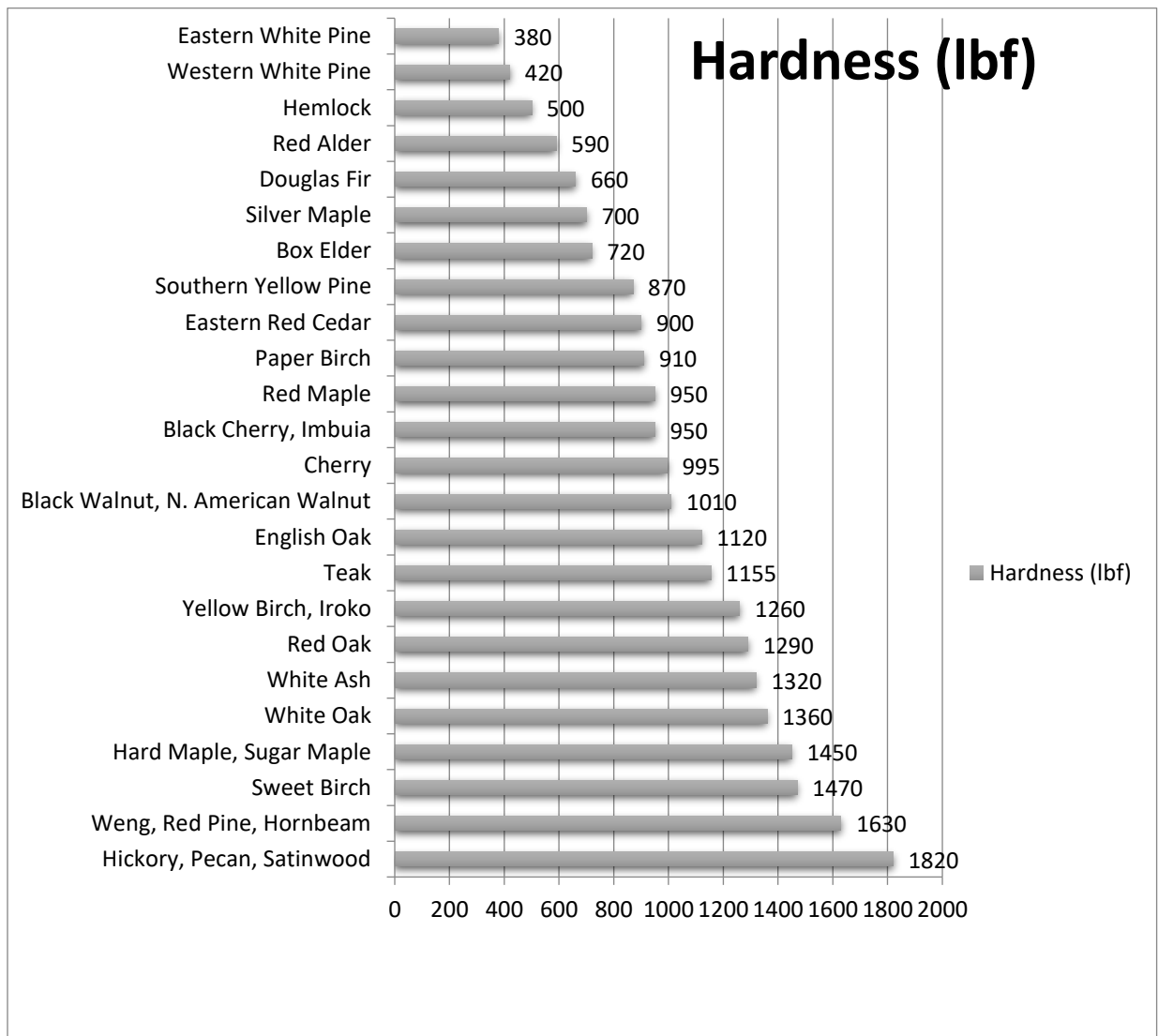

Pocket Depth Adjustment

The Screw Pocket Machine can be adjusted for varying pocket depths. The pocket depth adjustment handle is located on the front of the machine (Fig 14). Turn the handle **counterclockwise** to cut **shallower** pockets, and **clockwise** to cut **deeper** pockets. One revolution of the handle will move the pocket approximately 1/64".

Use the, **red Depth Gauge** (Fig. 14), at the back of the clamp guard, as a reference to set the screw pocket to the desired depth. **The Depth Gauge** is factory set to indicate the center of the drilled hole position. The **Depth Gauge** is adjustable, and can be set to indicate either the depth of the pocket or the drilled hole position, see "**Depth Gauge**" next section, for details.

NOTE: For the strongest joint and to reduce the possibility of the screw over penetrating, the screw hole should be centered in the thickness of the material for most applications.

NOTE: There are two factors and three variables to consider when setting up and calibrating the Screw Pocket Machine.

Two Factors

1. Material Thickness (both parts, equal or dissimilar?).
2. Screw Length (desired).

Three Variables

1. Depth setting of Pocket (determines screw location, up/down)
2. Fence Location (position) (determines screw penetration)
3. Screw Length (practical) (determines holding force and screw penetration)

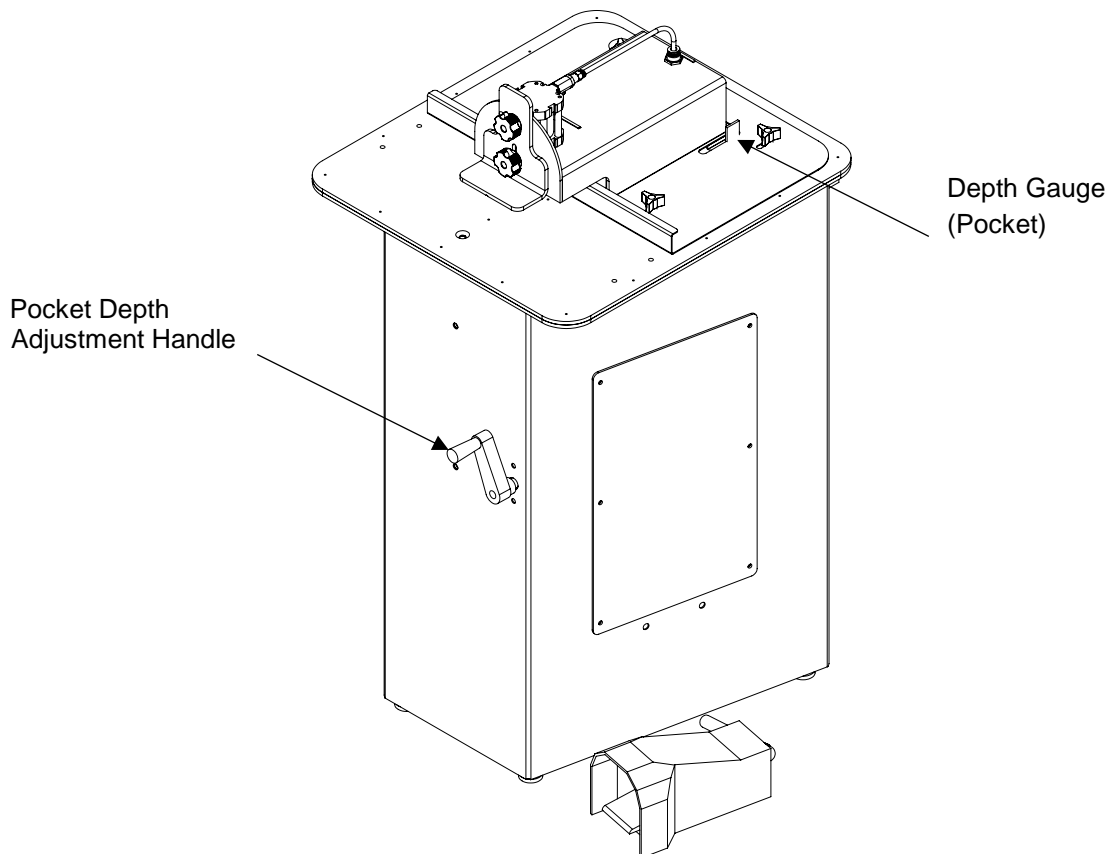

Figure 14: Pocket Depth Control and Depth Gauge



When cutting deep pockets, it may be necessary to reduce cycle speed. Using fast cycles along with deep pockets in hard materials can stall the machine or break the router bit and/or drill bit.

Selecting Screws

There are many types and sizes of pocket hole screws available. When choosing the appropriate screw for your applications always choose **high quality, self-tapping** screws designed for pocket holes. Low quality screws can split material and the heads of the screws can easily break off.

Common “types” of pocket hole screws include:

- **Fine Thread** – good choice for hard/dense woods.
- **Coarse Thread** – good choice for soft woods and panel products, E.g. MDF, Plywood, Melamine, etc.
- **Washer Head** – good choice for softwoods and panel products (good surface with head and less chance of pulling through web).
- **Pan Head** – good choice for hardwoods and thin materials (less chance of head protruding from a shallow pocket).

Typical materials and coatings for screws:

- **Zinc plated steel** – good choice for interior work, not exposed to moisture.
- **Black phosphate coated steel** – good choice for interior work, not exposed to moisture.
- **Exterior coated steel** – good choice for exterior work or interior work exposed to light to moderate moisture.
- **Stainless Steel** – best choice for exterior work or any work exposed to moisture or when joining treated lumber.

Common screw length and material thickness guide (typical applications):

- **1” screw; 1/2” – 5/8” thick material.**
- **1-1/4” screw; 3/4” – 7/8” thick material.**
- **1-1/2” screw; 1” – 1-1/8” thick material.**
- **2” screw; 1-1/4” – 1-3/8” thick material**
- **2-1/2” screw; 1-1/2” thick material**

NOTE: The above information is only a guide, your specific materials and conditions may require alterations to screw size, types, materials or machine settings. Always test, in scrap material, the pocket location and screw size before joining good material. This is especially true when joining dissimilar thicknesses or, for example, when joining a side panel to a face frame.

Depth Gauge

The *red* (Pocket) Depth Gauge (Fig. 15) is factory calibrated to indicate the approximate center of the screw depth (where the screw exits the stock being machined). The Depth Gauge can be recalibrated to indicate the depth of the pocket, depending on preferences and applications. The Depth Gauge automatically moves when the Pocket Depth Adjustment handle is adjusted. To calibrate the Depth Gauge:

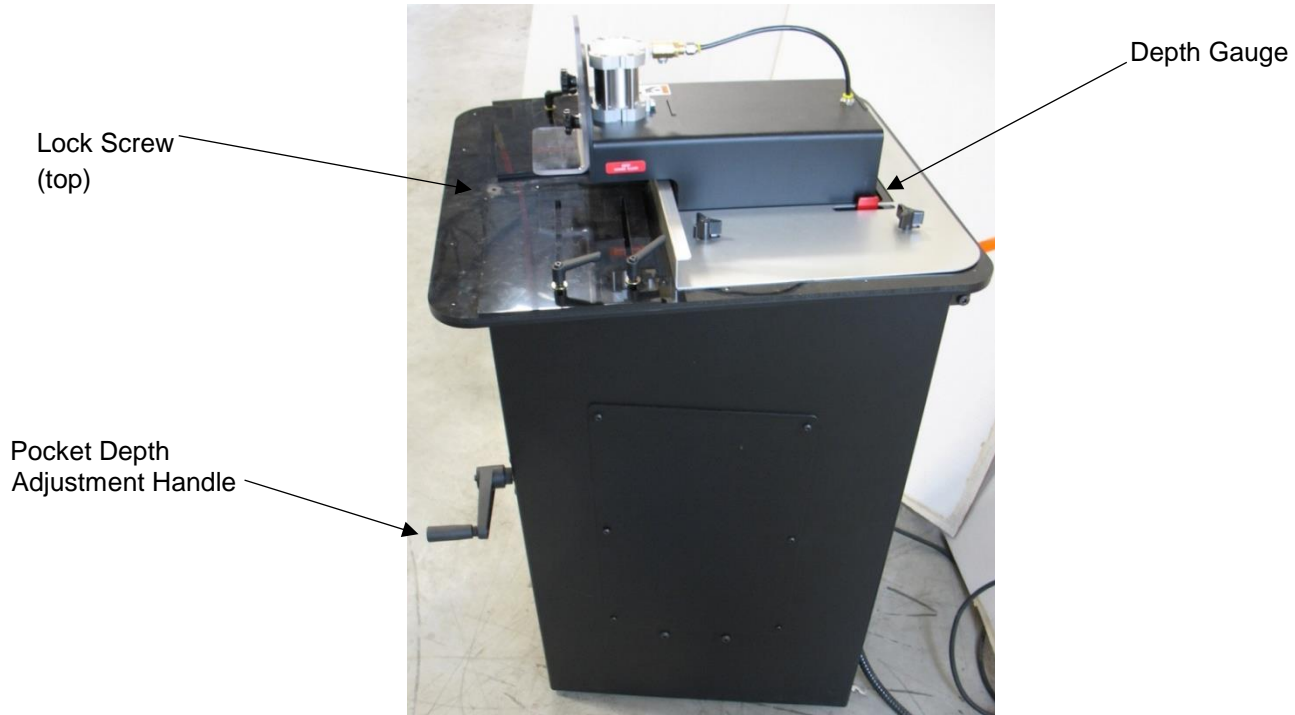

Figure 15: Depth Gauge

Calibrating the depth gauge:

1. Make a test cut in scrap material the same thickness as material to be processed. (See “Operation” section)
2. Place test piece next to Depth Gauge (Fig. 15).
3. Measure distance (up or down) the Depth Gauge needs to move to align with sample cut and desired calibration. Write this measurement for reference.
4. Disconnect power and air to machine (observe Lockout/Tagout procedures).



Unplug tool and disconnect air supply before making adjustments or installing bits. Observe appropriate Lockout/Tagout procedures to insure the tool cannot accidentally be powered.

5. Remove lock screw from top of machine and open top (Fig. 15).
6. Make a pencil mark where the Depth Gauge intersects the Router Arm and wrap the line around the front of the Depth Gauge. The wrapped line is needed if lowering the Depth Gauge.
7. Loosen the two bolts holding the Depth Gauge (Fig. 15).

8. Slide the Depth Gauge up or down the same distance as the earlier measurement. Use the pencil line and top of Router Arm as references for measurement and to determine movement of Depth Gauge.
9. Hold the Depth Gauge in position and tighten both bolts.
10. Close top and secure top with bolt.
11. Connect power and air.
12. Make a test cut and confirm Depth Gauge is properly aligned. Readjust if necessary.

Pocket Hole Positioning

Web, 5/8" min.



Figure 16: Web dimension, 5/8" minimum

Pocket Hole Location:

Pocket Holes should be positioned at least 5/8" in from end of stock (Web, Fig. 16)) and a minimum of 3/8" (Offset, Fig. 17) from edge. This provides for a strong joint. Stock wider than 1-1/4" should have a minimum of two pocket holes and more pocket holes if over 3" wide. When joining cabinet sides to a face frame, or other large panel processing, pocket holes should be spaced every 6-8" and 2" in from the end (offset).

Offset, 3/8" min.



Figure 17: Offset dimension, 3/8" minimum

Fence Adjustment

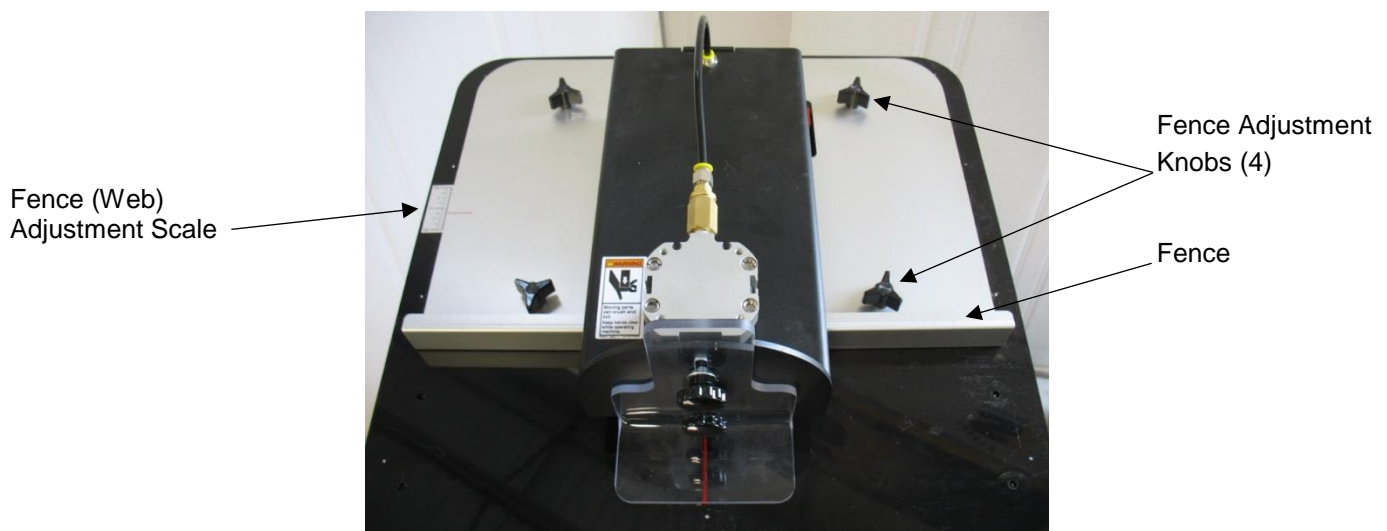

Figure 18: (Web) Fence Adjustment

The Fence (Fig. 18) aligns the edge of stock in the proper location for the pocket hole and length of the “Web” (Fig. 16), (distance from end of stock to end of pocket hole). The Fence is adjustable and can be positioned for various screw lengths and material thicknesses. It is important to have the fence adjusted properly, if the Web is too short or too long it can create a weak joint. If too short the Web will not have enough strength and the screw could over penetrate. If the web is too long, the screw will not penetrate enough into the mating material.

NOTE: The typical Fence setting for joining two 3/4” thick pieces of material using 1-1/4” screws is approximately 5/8”. The web length is approximately 5/8”. Fine tuning the Fence for specific applications, materials and hardware may be required. Always process a test piece after making adjustments.

The Fence is secured to the table with four knobs. To adjust the Fence, loosen the four knobs and slide the Fence forward or back. A scale (Fence (Web) Adjustment Scale, Fig. 18) is attached to the left side of the table (as you face the machine) with reference line built into the Fence. When the Fence is positioned properly tighten the four knobs to secure the Fence.

To calibrate the Fence:

1. Make a test cut in scrap material (of equal thickness to stock material).
2. Install a screw into test pocket hole and seat firmly.
3. Confirm screw will not penetrate through face of mating material, or penetrate past the end of mating material.
4. Confirm screw has sufficient length through pocket to secure mating material.
5. Confirm pocket is “Offset” (Fig. 17) a minimum of 3/8” from side of material.
6. Confirm pocket “Web” (Fig. 16) is a minimum of 5/8” from end of material to end of pocket.
7. A. If screw does not properly extend through pocket hole, move Fence back.
B. If screw over extends through pocket hole, move Fence forward.
C. If screw penetrates through face of mating material, move Fence back and/or use a shorter screw.

NOTE: When adjusting the fence, the “Web” should be approximately 5/8”.

Perpendicular Guide Adjustment

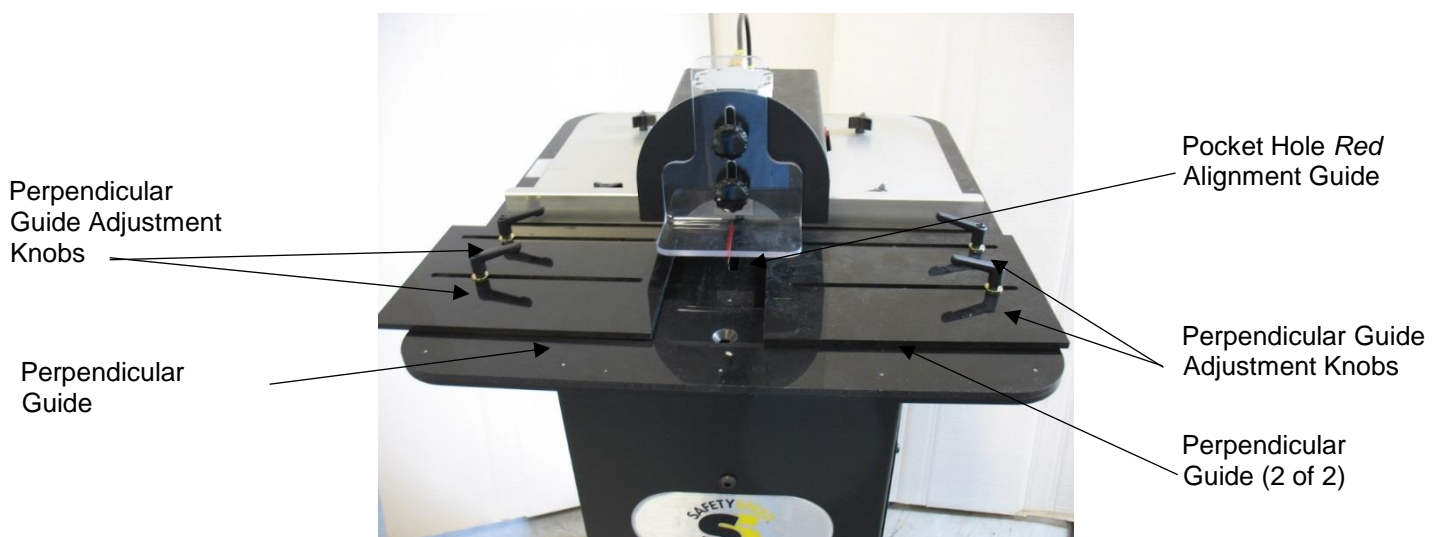

Figure 19: Perpendicular Guide Adjustment

The two Perpendicular Guides can be adjusted to properly position rails or other narrow material for fast and accurate repetitive pocket holes. The Guides establish the “Offset” for the pocket holes. Each Guide is held in place with two adjustment knobs. To adjust, loosen the two knobs, slide the Guide to the desired location, confirm guide is perpendicular to the fence and tighten the two knobs. Both Guides adjust in the same manner.

NOTE: The “Pocket Hole Red Alignment Guide” indicates the approximate middle of location of the pocket to be cut.

One method to set the Perpendicular Guides is to adjust one for the correct offset from one edge of the stock. Then to set the second Perpendicular Guide to the correct offset from the other edge of the stock. This allows quick positioning from side-to-side when processing two pocket holes in a “rail” or similar applications.

NOTE: Some applications may require more than two pockets per part. For example, if the part is over 3” wide, at least two pockets should be cut.

MAINTENANCE



To reduce the risk of injury, always unplug the tool before doing any maintenance. Never disassemble the tool or try to do any rewiring to its electrical system. Contact a qualified electrician for electrical repairs. Always follow lockout/tag out procedures when servicing electrical equipment.

General Maintenance

Keep the machine in good repair by adopting a regular maintenance program. Before each day’s use, examine the general condition of the tool, and inspect the guards, switches and power cord for damage. Check for loose bolts, misalignment, binding of moving parts, improper mounting, broken parts, and any other condition that may affect its safe operation. If abnormal noise or vibration occurs, turn the machine OFF immediately and have the problem corrected before further use. Do not use a damaged machine. Tag damaged machines “DO NOT USE” until repaired.

Cleaning

Daily:

- Check pneumatic oil level and add oil if necessary (if so equipped).
- Clean all dust and debris from the vents in the motor housing.
- Keep the handles clean, dry and free from oil and grease.

Use only mild soap and a damp cloth to clean the tool, because certain cleaning agents and solvents are harmful to plastics and other insulated parts. Some of these include: gasoline, turpentine, lacquer thinner, paint thinner, chlorinated cleaning solvents, ammonia, and household detergents containing ammonia. Never use flammable or combustible solvents around tools.

⚠️ WARNING

To reduce the risk of injury, electric shock, and damage to the tool, never immerse the router or drill in liquid or allow a liquid to flow inside it.

Maintaining Motors

For motor maintenance instructions see the included motor manuals. If your motor manuals are missing contact SSM for a replacement. Clean dust and debris from cooling fans (if so equipped).

Brushes (electric motors only):

Both brushes for an electric motor must be a minimum of 3/8" long and not cracked, chipped or dirty. Wipe with a clean cloth and reinstall if not requiring replacement. Contact Safety Speed Mfg. for replacement brushes (763)-755-1600.

SERVICE

Removing Motors

⚠️ WARNING

Unplug tool and disconnect air supply before making adjustments, changing motors or installing bits. Observe appropriate Lockout/Tagout procedures to insure the tool cannot accidentally be powered.

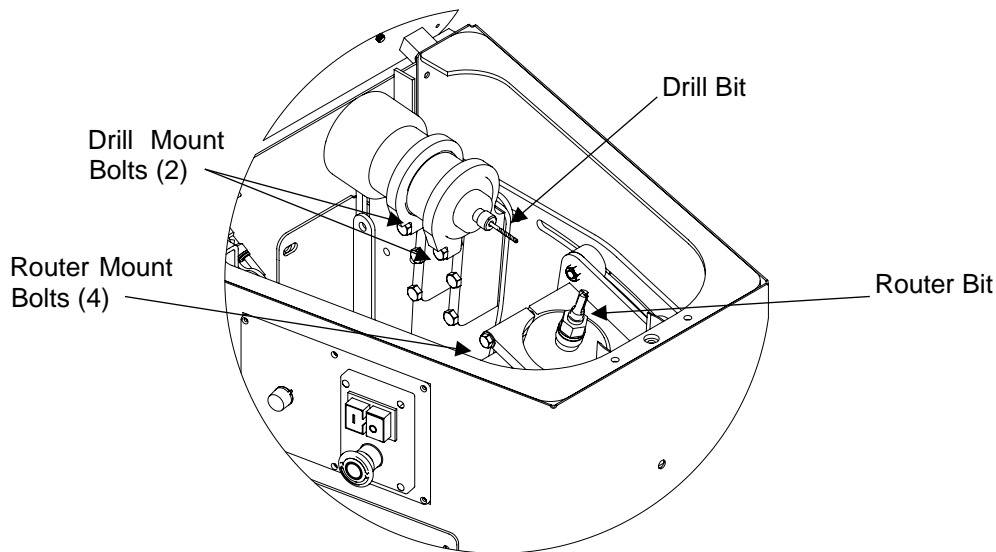

Figure 20: Motor removal (SPM301 shown)

1. Disconnect and lock off the power supply.
2. Remove bit(s), see "Installing a Router Bit" or "Installing a Drill Bit".
3. Loosen the bolts on the motor mount(s). Router, (Fig 20 or 21), or drill motor, (Fig 20 or 21). For **SPM301 only**, skip to step 7.
4. **SPM301HD only:** Disconnect air supply by pushing IN on the air line while pulling back (away from air line) on the collar of the air connection, then pull hose from connection while holding collar back.

5. **SPM301HD router only:** Remove the three lock nuts from Router Mount Bolts (Fig. 21).
6. **SPM301HD router only:** Loosen the three Router Mount Bolts (Fig. 21). Support the motor by hand while removing the three Router Mount Bolts.
7. Support the motor by hand and carefully pull it free of the motor mount(s)

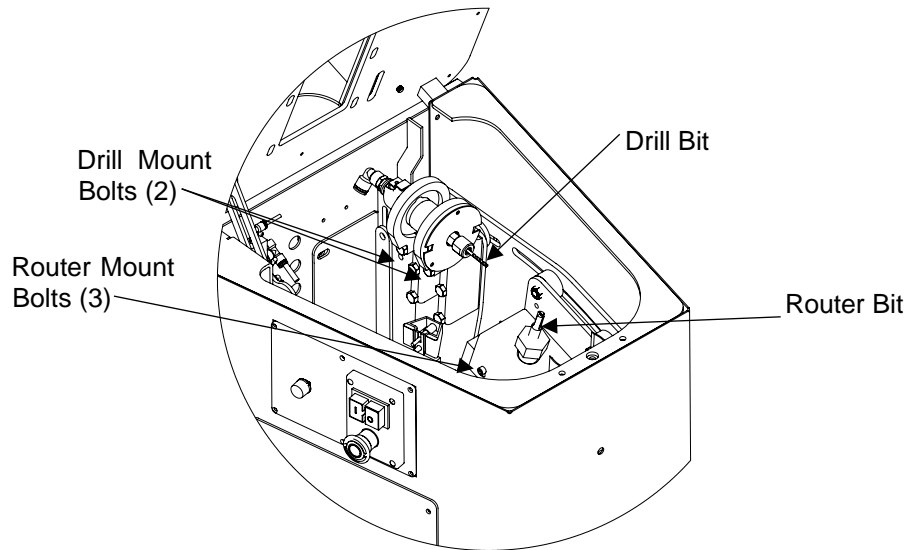

Figure 21: Motor Removal (SPM301HD shown)

Installing Motors

⚠ WARNING

Unplug tool and disconnect air supply before making adjustments, changing motors or installing bits. Observe appropriate Lockout/Tagout procedures to insure the tool cannot accidentally be powered.

⚠ WARNING

Electric motors for the Screw Pocket Machines are designed specifically for Safety Speed Manufacturing Screw Pocket Machines and should only be repaired or replaced with exact replacement components from Safety Speed Manufacturing. Call SSM (763)-755-1600 Technical Service for details.

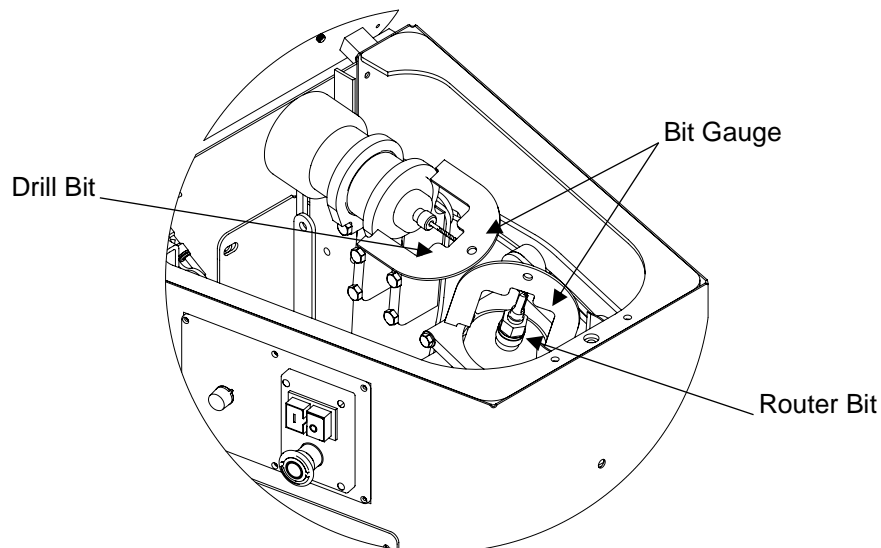

Figure 22: Installing Motors (SPM301 shown)

1. Install the appropriate bit into the collet, finger tighten. A Drill Bit should extend approximately 1-1/4" from the end of the collet, (Fig. 22). A Router Bit should extend approximately 1-5/8" from end of collet (Fig. 22). Tighten Collet. This setting is for motor installation reference only, do not cycle the machine until step 5 is complete!



Do Not power up or cycle the Screw Pocket Machine until the last step is complete.

2. Mount the motor into its bracket(s), (Fig. 22) using the appropriate Bit Gauge (Fig. 22) to assist in aligning the motor in the correct position. Tighten the bolts securing the drill motor and/or router motor.
3. Position the Bit Gauge (Fig. 22) against the drill mount (Fig. 22) or router mount and confirm the bit is up against the bottom of the Bit Gauge.
4. **SPM301HD only.** Re-install the air line to the drill motor. Pull back on the collar of the air line fitting. Push the line into the fitting while twisting slightly. The collar will "click" into place when the line is seated properly.
5. If the bit(s) are not properly touching the Bit Gauge, loosen the collet nut, reposition bit and tighten the collect nut securely. See "Installing a Router Bit" and "Installing a Drill Bit" for detailed bit adjustment instructions.



Always use supplied Bit Gauge (Fig. 22) when installing router or drill motors or bits. Failure to do so could result in the bits colliding with each other or the machine table when the machine is cycled. If your guide is missing or damaged contact SSM for a replacement.

Adjusting the Guide Arms

The Guide Arm Adjustment should be checked every 35-40 hours of operation. Bushing tension is correct when you can rotate the round black or gray nylon bushing by hand, but feel mild resistance.



Unplug tool and disconnect air supply before making adjustments or installing bits. Observe appropriate Lockout/Tagout procedures to insure the tool cannot accidentally be powered.

1. Loosen the lock nut (Fig. 23).

NOTE: There are four Nuts, Bolts and Nylon Guides to be checked.

2. Tighten bolt (Fig. 23) until slight resistance can be felt when rotating the nylon bushing (Fig. 23) by hand.
3. Tighten nut. When the bushings are properly adjusted you will be able to turn the bushing easily by hand, but will feel a slight drag. If this is too loose the tool will chatter in the cut. If it is too tight, the machine will overload and motor life will be shortened. Repeat the above procedure for all four bushings.

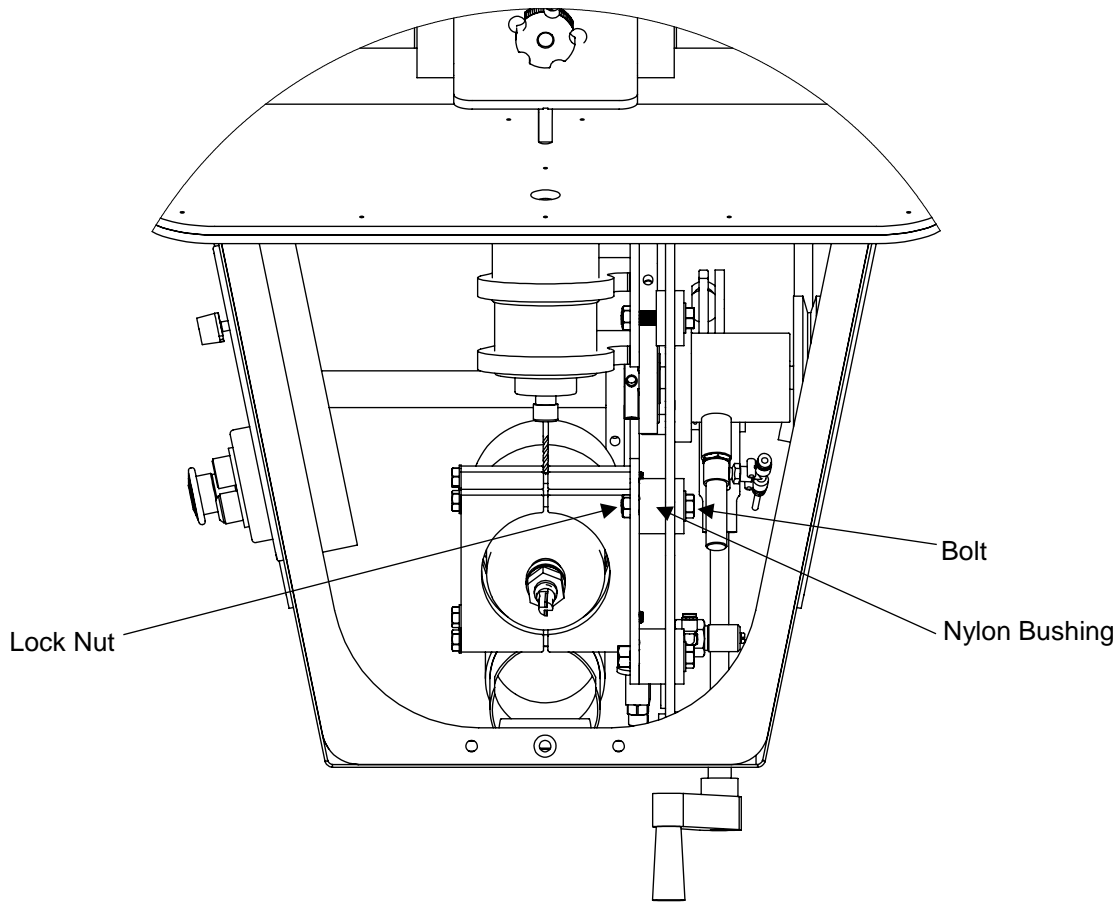

Figure 23: Guide Arm Adjustment (Top view with cover open)

Lubricating the Guide Arms & Bushings

The guide arms and bushings should move smoothly over the frame plate. If the bushings become caked with dust or debris, the bushings may get stuck or may not slide smoothly. Periodically clean the bushings with a damp cloth, following the directions under "Cleaning". Then use a dry lubricant such as a spray silicone. Other lubricants cause dust and debris to collect on the bushings and contaminate the bearings.



**Unplug tool and disconnect air supply before making adjustments or installing bits.
Observe appropriate Lockout/Tagout procedures to insure the tool cannot accidentally be powered.**

Replacement Parts & Repairs

Contact your Safety Speed Manufacturing dealer or SSM for technical advice and repair parts **(763) 755-1600**. Much information can be found at www.safetyspeed.com. Have your model number and serial number available when calling for parts or advice. See inside front cover, of this manual, for serial label location and information.

Adjusting the 3-Way (poppet) Valve



**Unplug tool and disconnect air supply before making adjustments or installing bits.
Observe appropriate Lockout/Tagout procedures to insure the tool cannot accidentally be powered.**

The 3-Way (poppet) Valve is located on the inside, front wall of the cabinet approximately midway down (Fig. 24). This valve controls the air cycle to release the pneumatic clamp. If the 3-Way valve is not positioned properly the pneumatic clamp may not release properly.

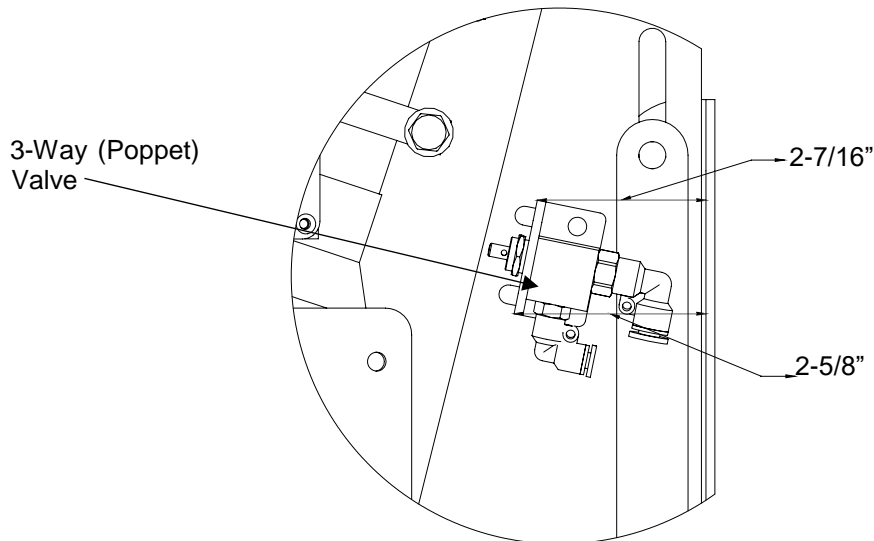
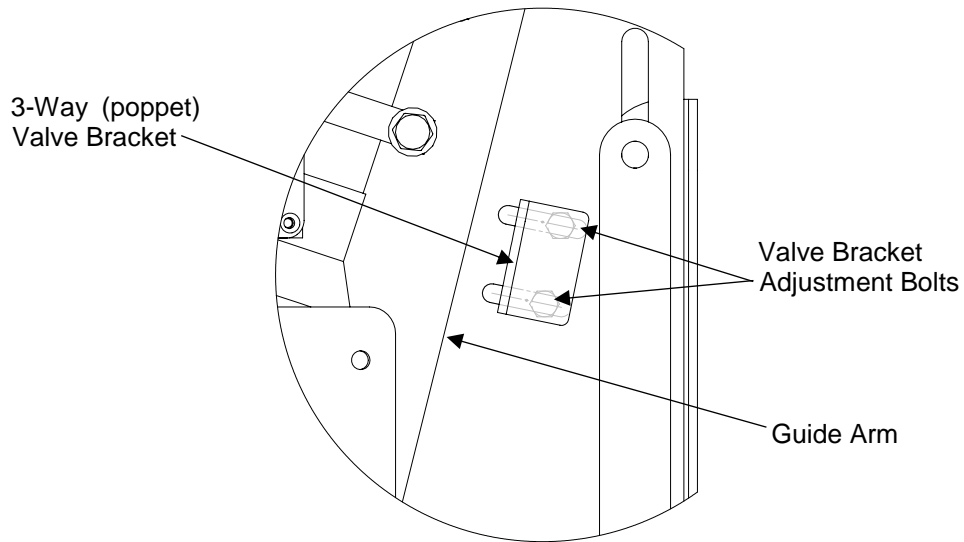

Figure 24: 3-Way (poppet) Valve position (side view)

1. Loosen both Valve Bracket Adjustment Bolts (Fig. 25).
2. Finger tighten both Valve Bracket Adjustment Bolts so the Bracket can be positioned by hand.
3. Position the Bracket and Valve so the top (front) of the valve is 2-7/16" from the large, gray mounting plate at the front of the machine (Fig. 24).
4. Position the bottom (front) of the Valve so it is 2-5/8" from the large, gray mounting plate at the front of the machine (Fig. 24).

NOTE: The angle of the 3-Way Valve Bracket should parallel the angle of the Guide Arm (Fig. 25) which activates the valve.

5. Making sure the bracket and valve do not move, tighten the two Valve Bracket Adjustment Bolts (Fig. 25).
6. Confirm valve position. Readjust if necessary.



**Figure 25: 3-Way (poppet) Valve Bracket
(valve not shown for clarity)**

Dust Collection

Connecting the machine to a dust collection system is recommended. A 3" hose is included. 600 CFM is the minimum recommended air flow. Dust collection extends the life of bits by removing excess debris and it helps to cool bits and motors, extending the working life of both.

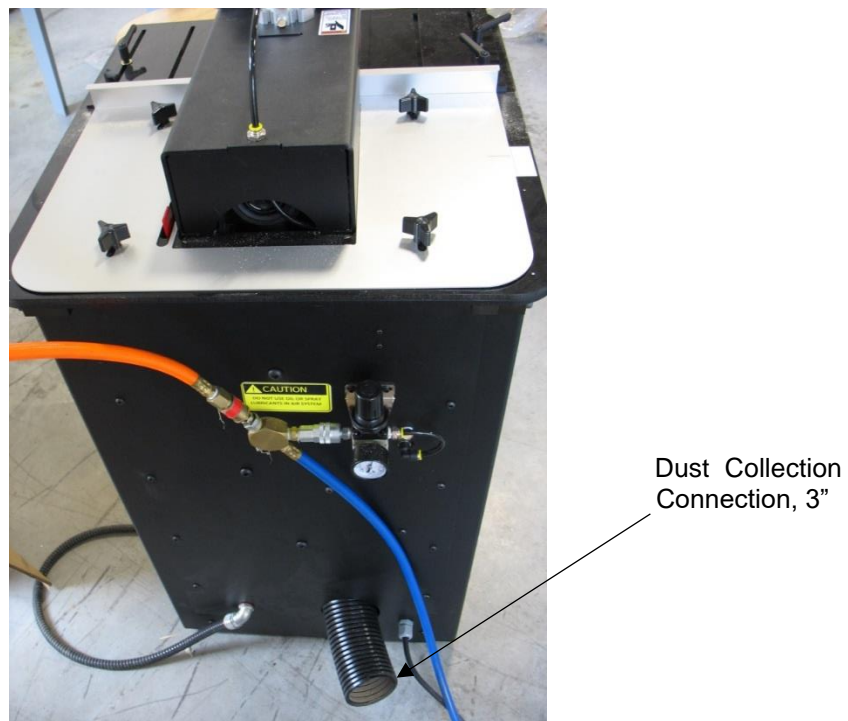

Figure 26: Dust Collection Connection (SPM301 shown)

Installation

1. Connect the 3" hose to your dust collection system. A minimum of 600 CFM is recommended.

NOTE: Dust collection adapters can be used to adjust to larger sized hoses or fittings.

Operation

Always turn the vacuum source on before starting the machine.

SPECIFICATIONS

Table III: Pocket Screw Machine Specifications

Model	Dimensions				Min. Stock Thickness	Max. Stock Thickness	Volts AC 1~
	Length	Height	Depth	Weight			
SPM301	22"/559mm	44"/1118mm	26"/660mm	350 lbs./159kg	.5"/13mm	1.5"/38mm	110
SPM301HD	22"/559mm	44"/1118mm	30"/762mm	375 lbs./170kg	.5"/13mm	1.5"/38mm	220
SPM301NE	22"/559mm	44"/1118mm	26"/660mm	350 lbs./159kg	.5"/13mm	1.5"/38mm	N/A

N/A = Not Applicable

ACCESSORIES AND TOOLS

<u>Description:</u>	<u>Model:</u>	<u>Part #</u>
9/64" Drill Bit	ALL	PH119
2 Flute 1/2" Shank	301	PH118
3 Flute 3/8" Shank	301 & HD	PH125
Tooling Setter	301	PH217
Tooling Setter	301HD	PH217HD
Extension Table	301	SP-A Table R
Panel Dolly	All	PD1

NOTE: Bits (Router Bits & Drill Bits) available from your SSM dealer or from SSM, call for details (763)-755-1600.



13943 LINCOLN ST. NE
HAM LAKE, MN 55304
Phone: 763-755-1600 Fax: 763-755-6080
sales@safetyspeed.com

www.safetyspeed.com

08/25/17